

© THIS DRAWING IS THE PROPERTY OF PROCHEM SERVICES AND CANNOT BE REPRODUCED OR USED WITHOUT THE COMPANIES EXPRESS PERMISSION.

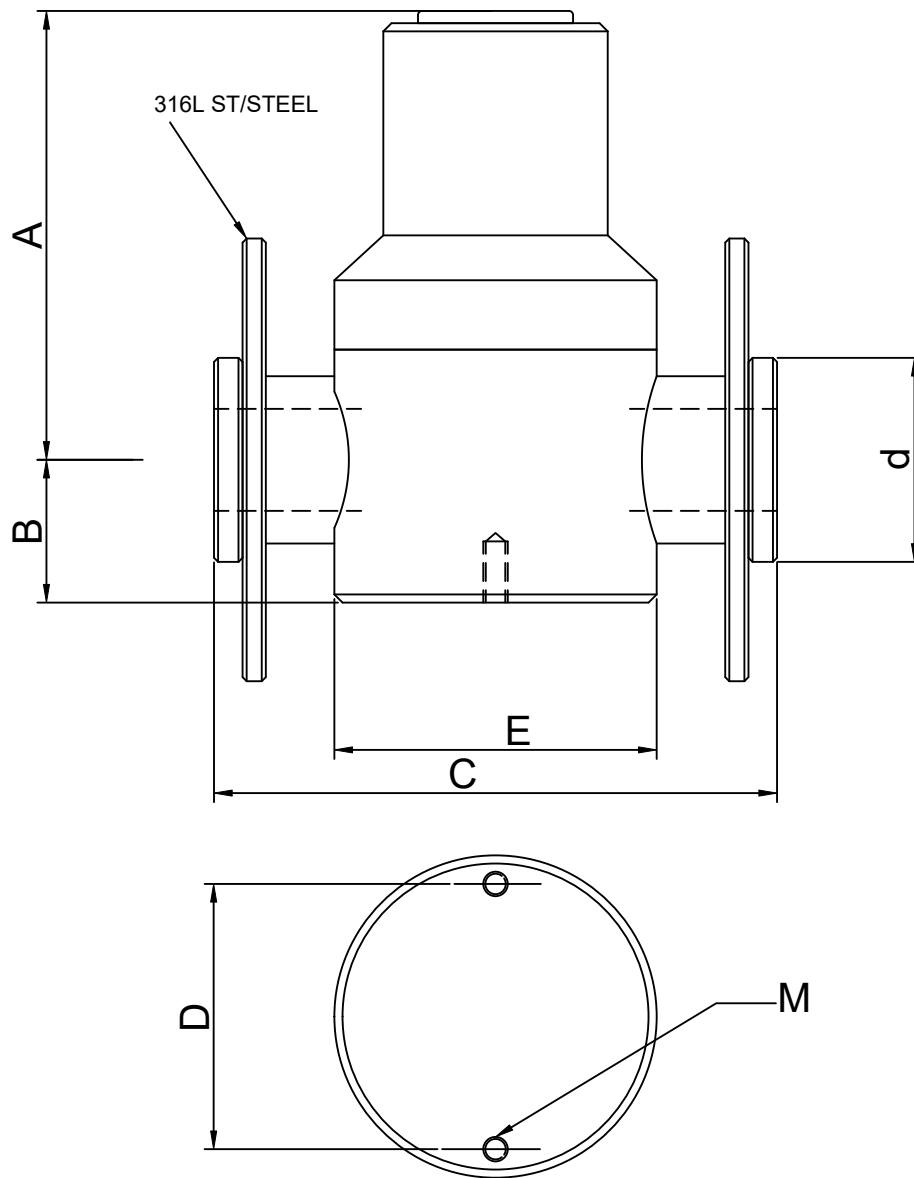

d			A	B	C	D	E	M
OD	DN	NB						
16	10	3/8"						
20	15	1/2"	88	26	113	40	52	M5
25	20	3/4"	108	33	124	50	64	M5
32	25	1"	108	35	138	60	79	M6
40	32	1 1/4"	116	42	157	70	89	M6
50	40	1 1/2"	140	46	186	80	109	M6
63	50	2"	156	57	216	100	128	M6

ALL DIMENSIONS IN mm UNLESS OTHERWISE STATED.
 DIMENSION 'C' ± 1.0 mm ALL OTHERS ± 0.5 mm.
 FLANGES ARE LAP TYPE STUB FLANGES WITH 316L STAINLESS STEEL BACKING RINGS.
 FLANGE DRILLINGS AS PER ORDER SPECIFICATION. I.E ANSI/ PN.

PROCHEM SERVICES LTD	
CONGLETON, CHESHIRE, CW12 2AD, ENGLAND	
DRAWING No. PS/91/173	REV 1
SUBJECT 1100 SERIES OUTLINE PLASTIC CONSTRUCTION - FLANGED.	

DRAWN	RB	DATE	19.09.12
REV 1	FLANGES NOW 316L ST/ST	REV	
REV		REV	