

© THIS DRAWING IS THE PROPERTY OF PROCHEM SERVICES AND CANNOT BE REPRODUCED OR USED WITHOUT THE COMPANIES EXPRESS PERMISSION.

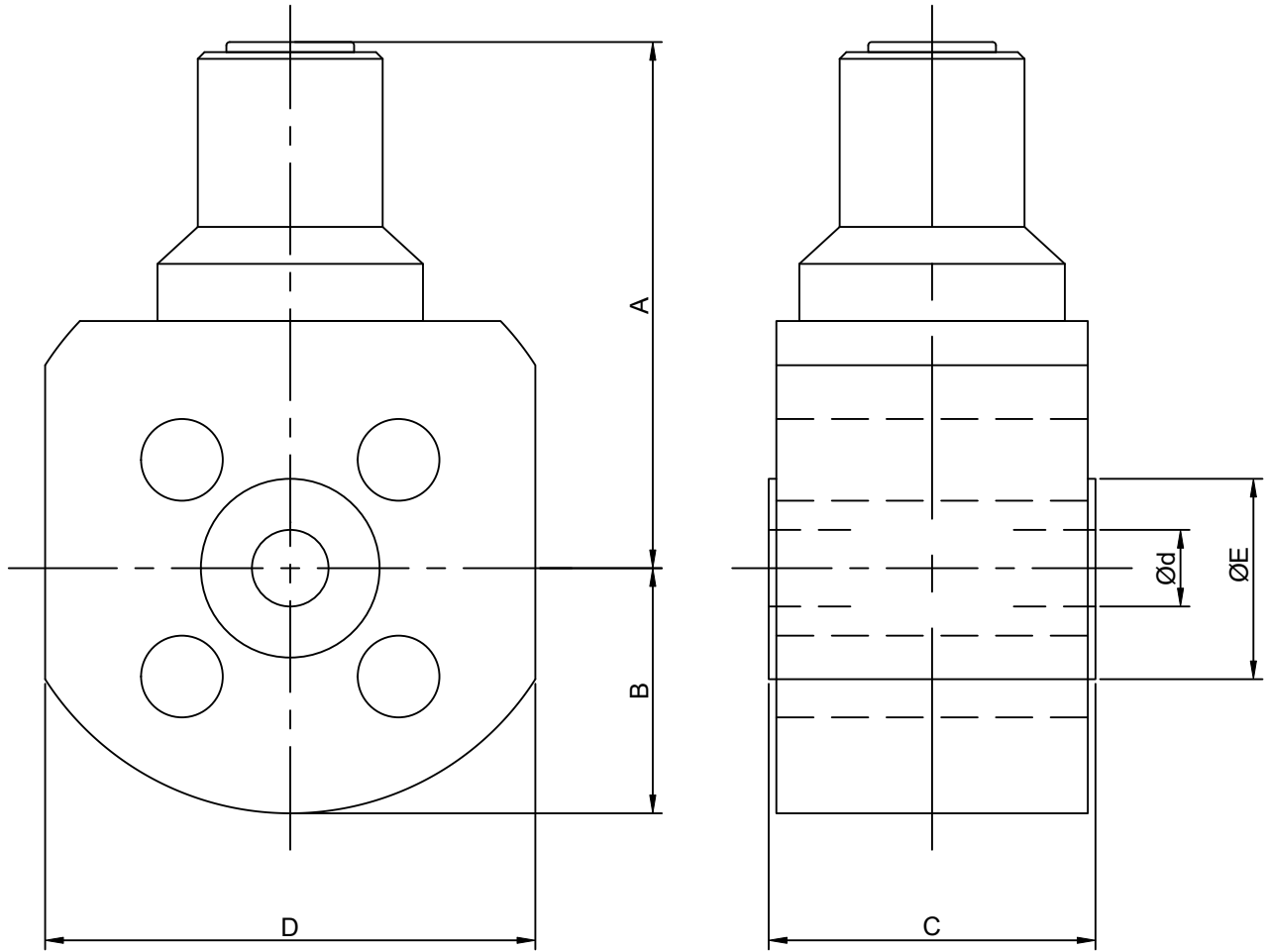

Ød			A	B	C	D	E
O.D	DN	NB					
20	15	1/2"	115	48	64	96	35
25	20	3/4"	134	53	70	106	43
32	25	1"	137	59	84	116	51
40	32	1 1/4"					
50	40	1 1/2"	180	76	114	151	73
63	50	2"	200	83	132	166	92

TOLERANCES ± 0.2mm UNLESS OTHERWISE STATED.

FLANGE DRILLINGS AS PER ORDER SPECIFICATION. I.E ANSI/ PN.

ALL DIMENSIONS IN MM UNLESS OTHERWISE STATED.

BODY M/C FROM SOLID BAR.

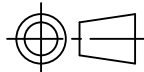

DRAWN	RB	DATE	12.10.12
REV		REV	
REV		REV	

PROCHEM SERVICES LTD	
CONGLETON, CHESHIRE, CW12 2AD, ENGLAND	
DRAWING No. PS/12/974	REV 0
SUBJECT 1100 SERIES WAFER BODY	