

© THIS DRAWING IS THE PROPERTY OF PROCHEM SERVICES AND CANNOT BE REPRODUCED OR USED WITHOUT THE COMPANIES EXPRESS PERMISSION.

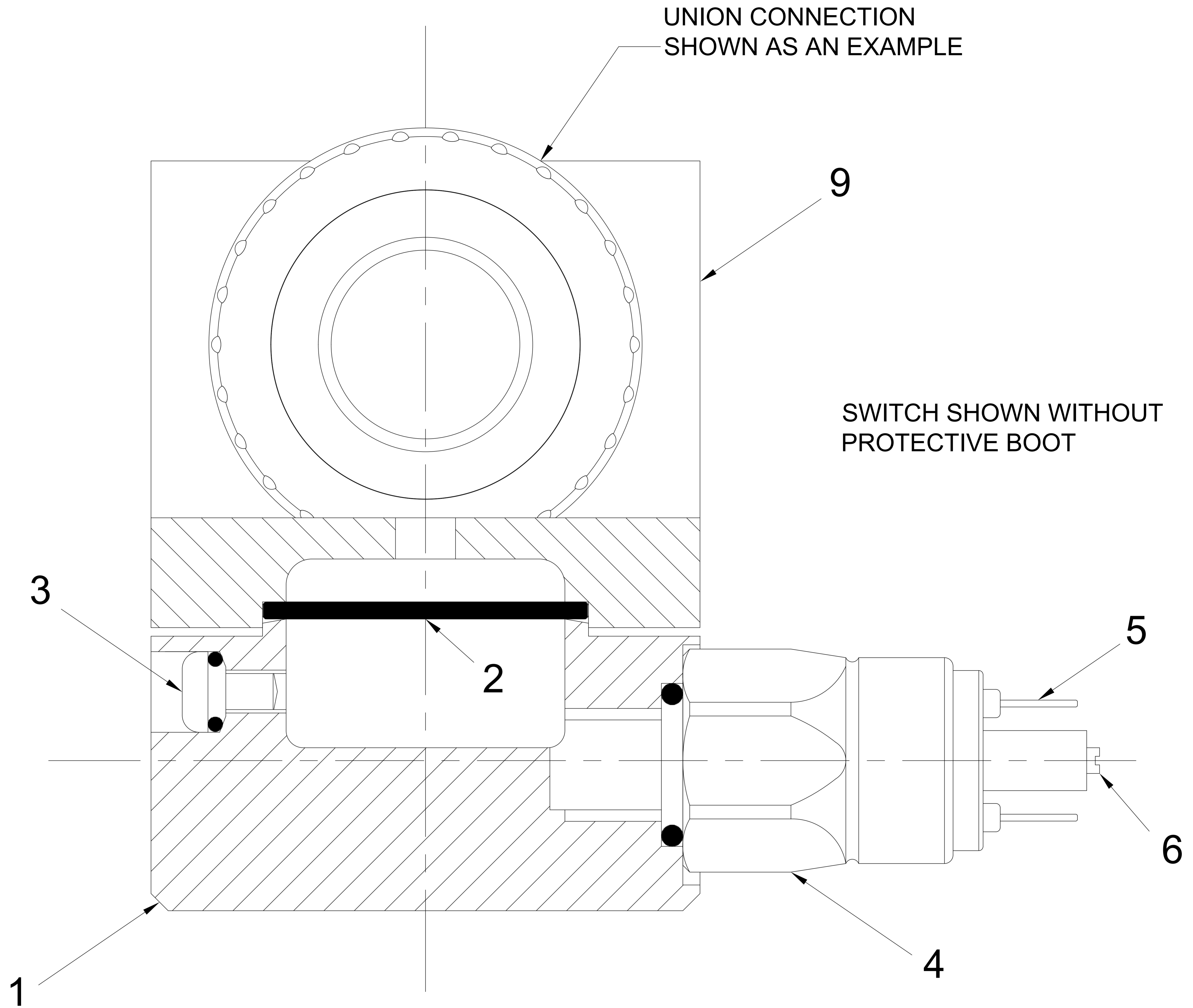

ITEM	DESCRIPTION
1	DIAPHRAGM HOUSING ASSEMBLY
2	DIAPHRAGM
3	CHAMBER FILLING SCREW & O-RING
4	PRESSURE SWITCH & O-RING
5	SWITCH CONNECTION SPADE LUGS
6	SWITCH ADJUSTING SCREW
7	ASSEMBLY CLAMP SCREWS (NOT SHOWN)
8	SWITCH PROTECTIVE BOOT (NOT SHOWN)
9	VALVE BODY

PROCHEM SERVICES LTD

CONGLETON, CHESHIRE, CW12 2AD, ENGLAND

DRAWING No. PS/94/302

REV 0

SUBJECT

XS SERIES PRESSURE
SWITCH OPTION ASSEMBLY

DRAWN RB DATE 13.02.13

REV REV

REV REV