

© THIS DRAWING IS THE PROPERTY OF PROCHEM SERVICES AND CANNOT BE REPRODUCED OR USED WITHOUT THE COMPANIES EXPRESS PERMISSION.

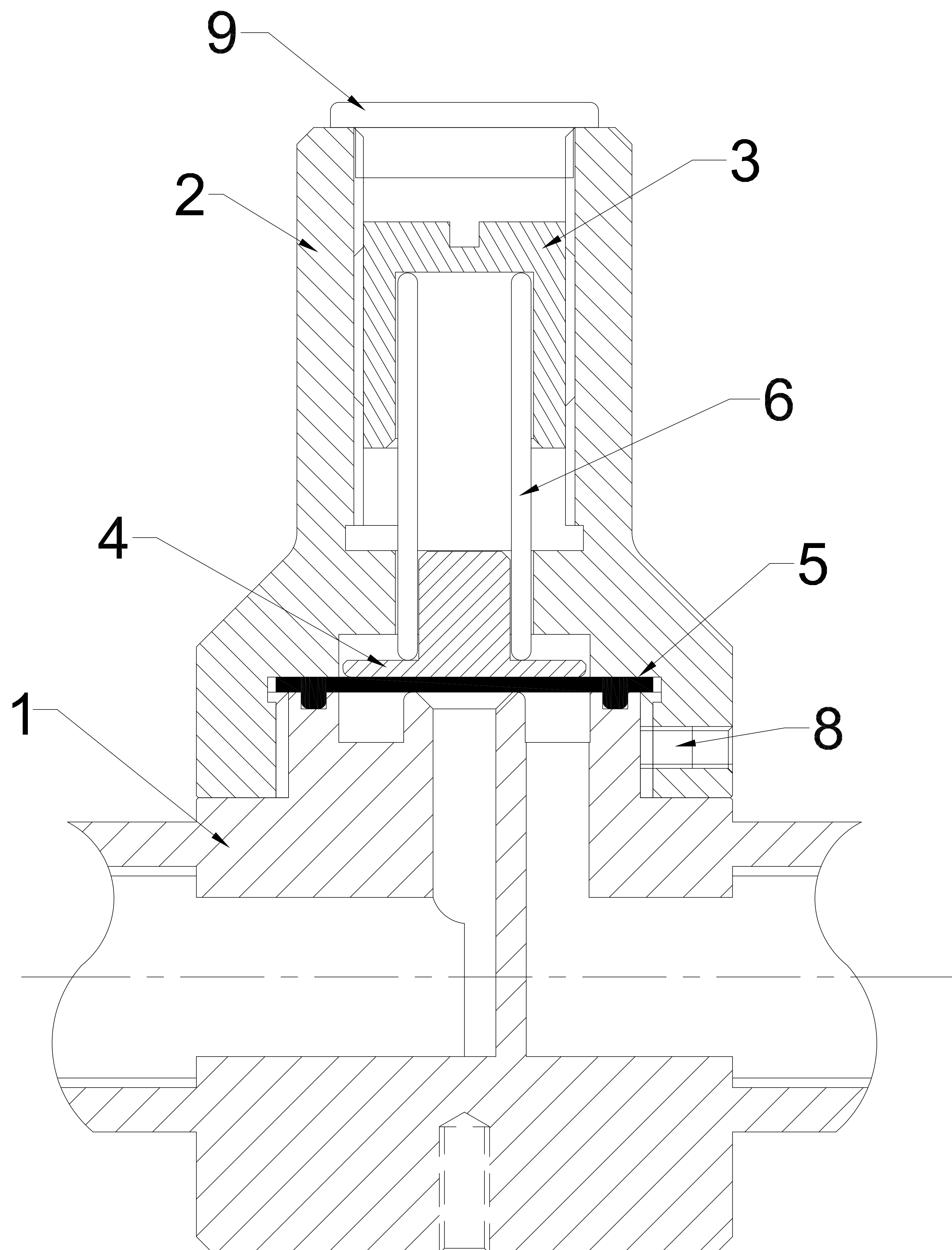

ACTUAL PIPELINE CONNECTIONS
OMITTED FOR CLARITY

ITEM	DESCRIPTION	MATERIAL	
1	BODY ASSEMBLY	AS ORDERED	
2	BONNET	PVC	
3	ADJUSTER SCREW	PVC	*
4	PRESSURE PAD	STEEL	*
5	DIAPHRAGM	AS ORDERED	*
6	LOADING SPRING	STEEL	*
7			
8	BONNET LOCK SCREW	316 ST/STEEL	
9	CAP	POLYPROPYLENE	

* RECOMMENDED SPARES

PROCHEM SERVICES LTD	
CONGLETON, CHESHIRE, CW12 2AD, ENGLAND	
DRAWING No. PS/92/243	REV 2
SUBJECT	
1100 SECTION & PARTS LIST	

REV		REV	
REV		REV	