

© THIS DRAWING IS THE PROPERTY OF PROCHEM SERVICES AND CANNOT BE REPRODUCED OR USED WITHOUT THE COMPANIES EXPRESS PERMISSION.

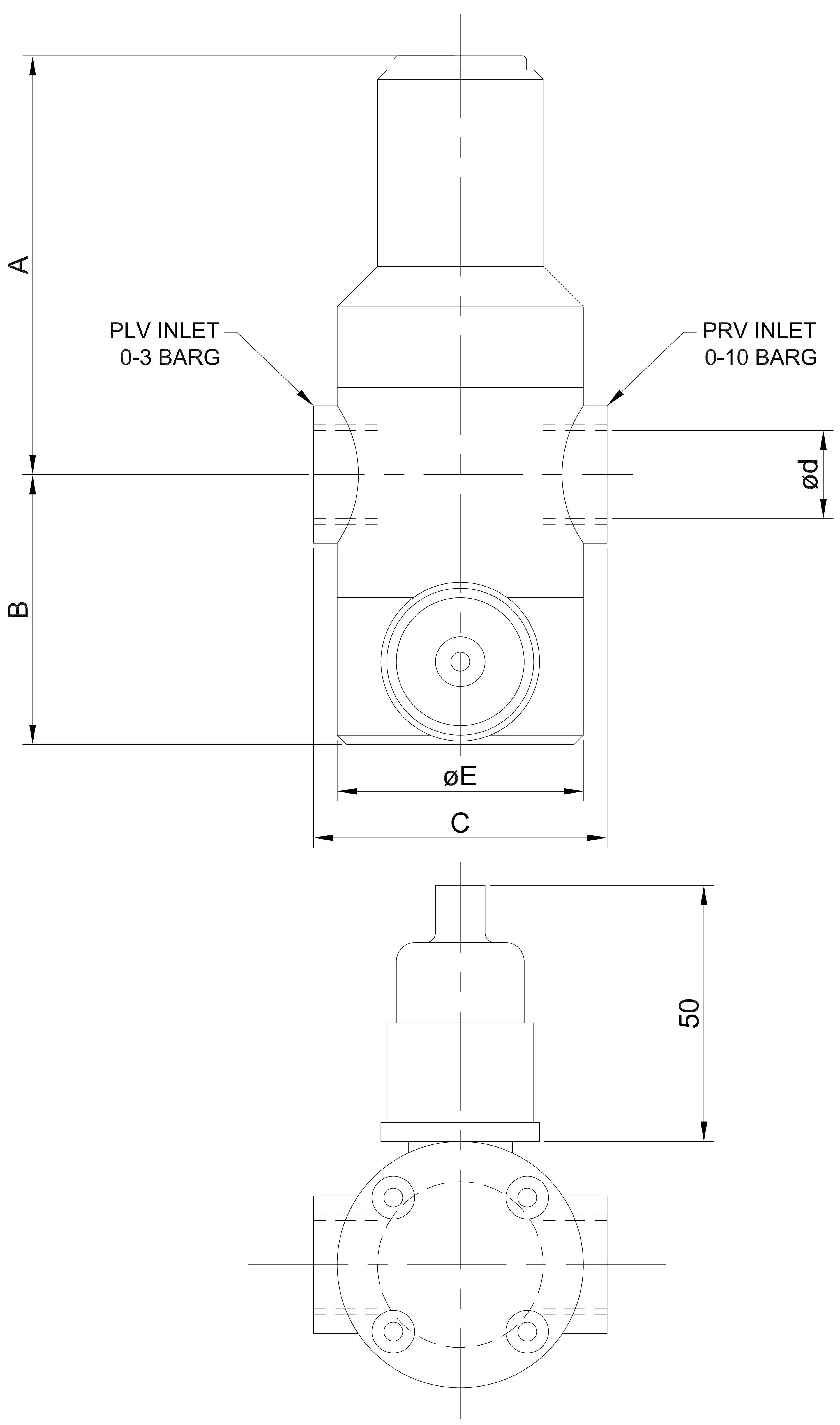

ød			A	B	C	D	E	F
O.D	DN	NB						
16	10	3/8"	88	54	72	—	52	
20	15	1/2"	88	54	72	—	52	
25	20	3/4"	105	67	86	—	64	
32	25	1"	108	67	102	—	79	
40	32	1 1/4"	116	76	123	—	89	
50	40	1 1/2"	140	80	140	—	109	
63	50	2"	156	91	163	—	126	

VALVE SHOWN WITH PROTECTIVE BOOT IN PLACE.

SWITCH ORIENTATION IS SUPPLIED AS SHOWN UNLESS OPPOSITE IS REQUESTED.

VALVES DO NOT HAVE HOLD DOWN FIXED SCREWS IN THIS CONFIGURATION.

SWITCH DIAPHRAGM HOUSING ASSEMBLY IS PVC WITH DIAPHRAGM MATERIAL TO MATCH VALVE DIAPHRAGM.

ALL DIMENSIONS IN MM UNLESS OTHERWISE STATED.

TOLERANCES: ± 0.5 UNLESS STATED  
DIMENSION 'C' ± 1.00 MM

SWITCH RATING 100 VA @ 40 V MAX

PROTECTION IP65 WITH BOOT  
IP00 WITHOUT BOOT

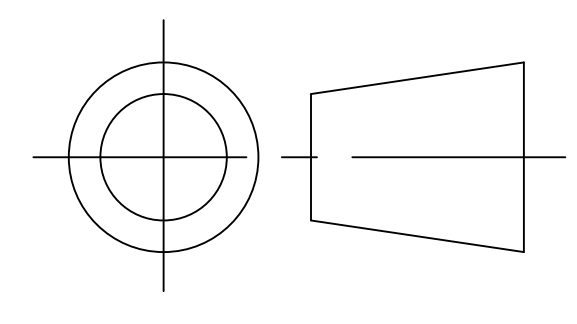

DRAWN	RB	DATE	28.09.12
-------	----	------	----------

REV		REV	
REV		REV	

<b>PROCHEM SERVICES LTD</b> CONGLETON, CHESHIRE, CW12 2AD, ENGLAND	
<b>DRAWING No. PS/12/969</b>	REV 0
SUBJECT 1100 SERIES WITH PRESSURE SENSOR - METAL SCREWED	