

© THIS DRAWING IS THE PROPERTY OF PROCHEM SERVICES AND CANNOT BE REPRODUCED OR USED WITHOUT THE COMPANIES EXPRESS PERMISSION.

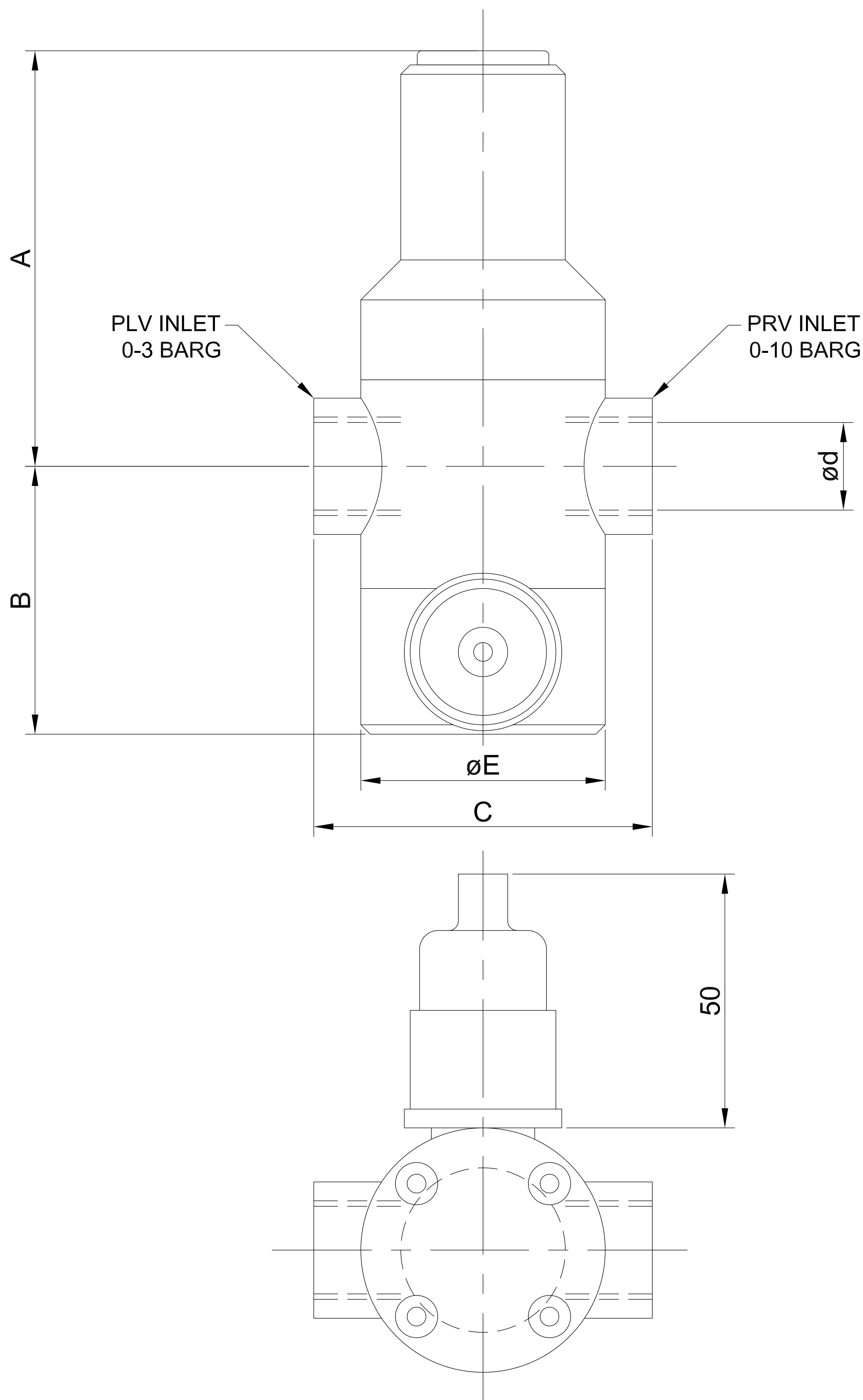

ød			A	B	C	D	E	F
O.D	DN	NB						
16	10	3/8"	85	57	72	—	52	
20	15	1/2"	85	57	72	—	52	
25	20	3/4"	102	67	86	—	64	
32	25	1"	105	65	102	—	79	
40	32	1 1/4"	113	74	123	—	89	
50	40	1 1/2"	137	78	140	—	109	
63	50	2"	153	89	163	—	126	

VALVE SHOWN WITH PROTECTIVE BOOT IN PLACE.

SWITCH ORIENTATION IS SUPPLIED AS SHOWN UNLESS OPPOSITE IS REQUESTED.

VALVES DO NOT HAVE HOLD DOWN FIXED SCREWS IN THIS CONFIGURATION.

SWITCH DIAPHRAGM HOUSING ASSEMBLY IS PVC WITH DIAPHRAGM MATERIAL TO MATCH VALVE DIAPHRAGM.

ALL DIMENSIONS IN MM UNLESS OTHERWISE STATED.

TOLERANCES: ± 0.5 UNLESS STATED
DIMENSION 'C' ± 1.00 MM

SWITCH RATING 100 VA @ 40 V MAX

PROTECTION IP65 WITH BOOT
IP00 WITHOUT BOOT

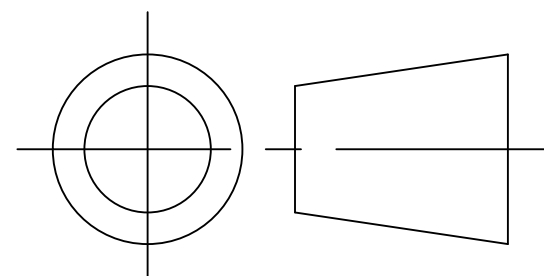

PROCHEM SERVICES LTD CONGLETON, CHESHIRE, CW12 2AD, ENGLAND	
DRAWING No. PS/12/966	REV 0
SUBJECT 1100 SERIES WITH PRESSURE SENSOR - PVC SCREWED	

DRAWN	RB	DATE	27.09.12
REV	REV		
REV	REV		